



- 1 Amp Output, 1NO
- Indicating LED
- Fixed or Adjustable Delays
- Screw Terminals or Push-On Tabs
- Voltages from 24 to 240VAC
- Epoxy Filled



### Operation

#### On Delay

When input power is applied to the MCS, the timing cycle begins. At the end of the timed period the load is energized. When input power is removed, the timing circuit is reset and the load is de-energized.

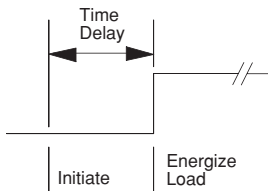

### Dimensions

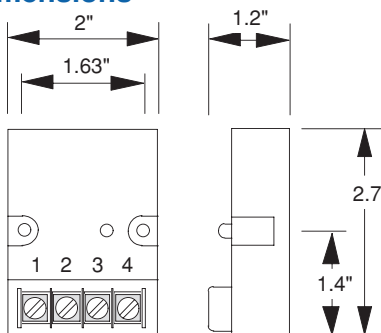

### Specifications

#### Electrical

**Input Voltage:** 24 to 240V,  $\pm 10\%$

**Frequency:** AC - 50/60Hz

DC - Filtered to Full Wave

#### Time Delays:

Type: Adjustable, Factory Fixed or Remote

Range: 100 Milliseconds to 5 Minutes

Repeat Accuracy:  $\pm 1\%$  with Fixed Conditions

Fixed Time Accuracy:  $\pm 20\%$  worst Case

#### Reset Times:

During Timing: 50 Milliseconds, Typical

After Timing: 5 Milliseconds, Typical

**Protection:** Varistor and/or R-C Network

**Power Consumption:** 5VA

#### Output Ratings:

Type: Solid State

Form: One Normally Open (1NO, Form A)

Non-Isolated

Rating: 1 Amp Continuous @ 25°C

Resistive: 100%PF

Inductive: 75-80%PF

15 Amps Inrush, Non-repetitive

30 mAmps to ensure Turn-on

Operations: 100,000 Cycles\*

\* Cycles were selected to satisfy minimum testing at UL.

#### Physical

**Mounting:** Surface, #6 Screws

**Termination:**

Screw or .25" Push-On Tabs

**Packaging:** Epoxy Filled

**Weight:** 4 Oz.

#### Ambient Temperatures

**Operating:** 0°C to 65°C

**UL Operating:** 0°C to 40°C

**Storage:** -30°C to 85°C

#### Notes:

Remote Timing Resistors - multiples of 2.7 megohms will increase the time delay by 1 minute  $\pm 20\%$ .

For adjustment codes 3 & 4 a jumper or resistor must be installed across terminals 3 and 4 to allow the timer to time out.

### Ordering Information

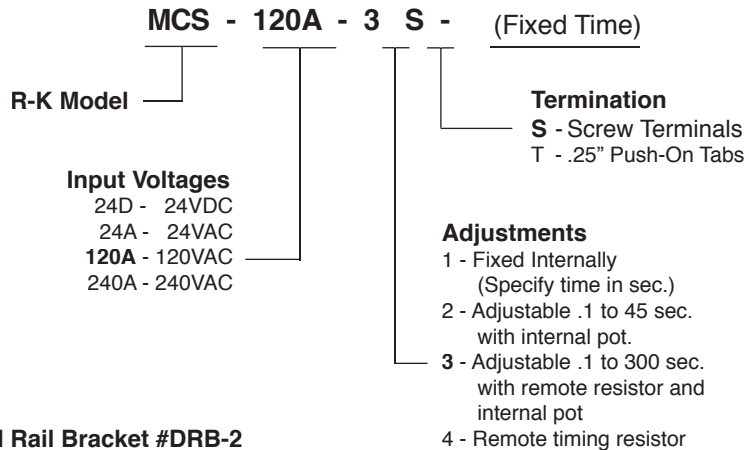

### Connections

The MCS operates with the Load in series with the timer. A Load must always be connected in series with the MCS to avoid damage.

MS = Load (Motor Starter)

C1 = Control Contact

